

Ref. Nr. 150.664



**LCP-192UV LED PANEL UV
192X 5MM**

MANUAL

Thank you for purchasing our company products. Please read these instructions carefully to enjoy optimum performance and a longer service life before you start to use.

CONTENTS

CONTENTS 2

Unpacking Inspections 3

 Unpacking instructions 3

 Checking the contents of the carton:..... 3

Safety Instructions 3

Product Overview 4

Functions Introductions 4

 Main Functions 4

 Operation Instructions 5

 Power supply connecting..... 5

 Power supply by storage battery 5

 Master/Slave mode..... 5

 Master/Slave connection 6

 Sound Active Mode 6

 Automatic Mode..... 6

 DIP switch setup..... 6

 DMX controllable 6

 DMX Value Functions 3 CH..... 7

 Value setup manual..... 7

 Diagram of value setup..... 7

 Setting DMX address by Dip switch 8

Maintenance 9

Specification 9

CE & R&TTE Declaration of Conformity..... 11



UNPACKING INSPECTIONS

Unpacking instructions

- Please unpack the carton and check the goods carefully when you receive it , if discover packing damage, shortage or quality problem, please notify the shipper and reject the goods.
- Before using this product, please read the instructions carefully and keep it in a safe place for future reference.

Checking the contents of the carton:

The product, Power cord, Instruction Manual



SAFETY INSTRUCTIONS

- Safety and regulatory power socket with high quality output should be used .
- Always connect the product to a grounded circuit to avoid the risk of electrocution.
- Never put tiny metal objects such as a screwdriver, iron wire and coins, etc. into the internal or stretch into the machine in case of short circuit .
- Please make sure to connect the proper voltage and do not higher or lower than that stated on the decal or rear panel of the product .
- Avoid hitting, crashing or squeezing with other objects in transportation. Never carry the product from the power cord or any moving part . Always use the hanging / mounting bracket or the handles.
- The product is used in door only .
- Never pull or tug on the cord and change it for another one , stop using it when it is damaged or becomes hot .
- Stop using the product once there is sparks when connecting with the power plug .
- Can not operate product with wet hands and never place it near the water or other liquid.
- Make sure there are no flammable materials close to the fixture while operating . Always install it in a location with adequate ventilation.
- Never replace the lighting source with different specification and rating when the original one is damaged.
- Make sure to power off before replacing the light source or the fuse. Never do it while it is on.
- The ambient temperature is no more than 40°C(104°F) .
- Never clean the fixture by water, thinner or other dissolved agent .
- Stop using the product in case of a serious operating problem and send it to our maintenance agent immediately. Never repair by non-professional workers .
- Avoid direct eye exposure to the light source while the product is on.

PRODUCT OVERVIEW

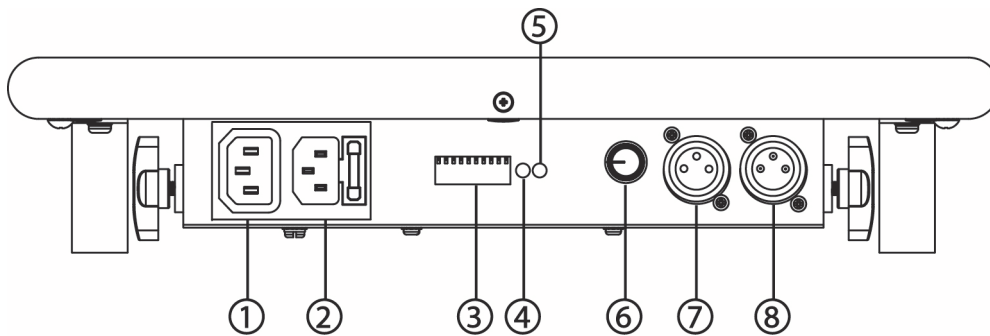

- | | |
|---------------------------------|--------------------------|
| 1. Power output | 7. DMX signal output |
| 2. Power input | 8. DMX signal input |
| 3. DMX Dip switch | 9. Four pin DC connector |
| 4. Signal indicator LED | 10. Safety Eyebolt |
| 5. Power indicator LED | 11. Hanging bracket |
| 6. Sound sensitivity adjustment | 12. LEDs |

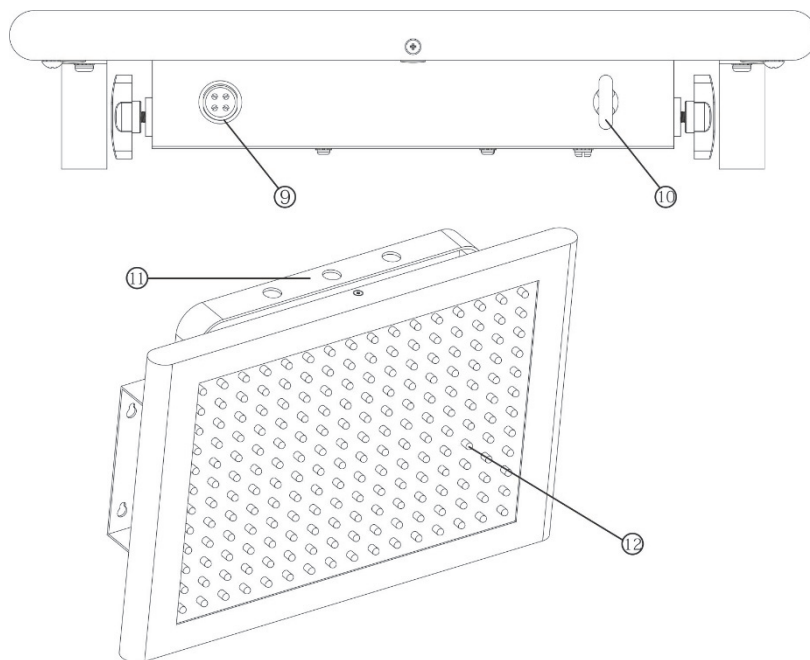

FUNCTIONS INTRODUCTIONS

Main Functions

- 3 DMX channels
- Automatic, sound active and master/slave mode
- Eight strobe speed effects by DIP switch, brightness and strobe speed can be adjusted
- Built-in automatic display, static color, dimmer and strobe functions

Operation Instructions

Power supply connecting

Two sockets in the product, Power In and Power Out , the product can be supplied power by the power out. Maximum output power of the socket is 600W .

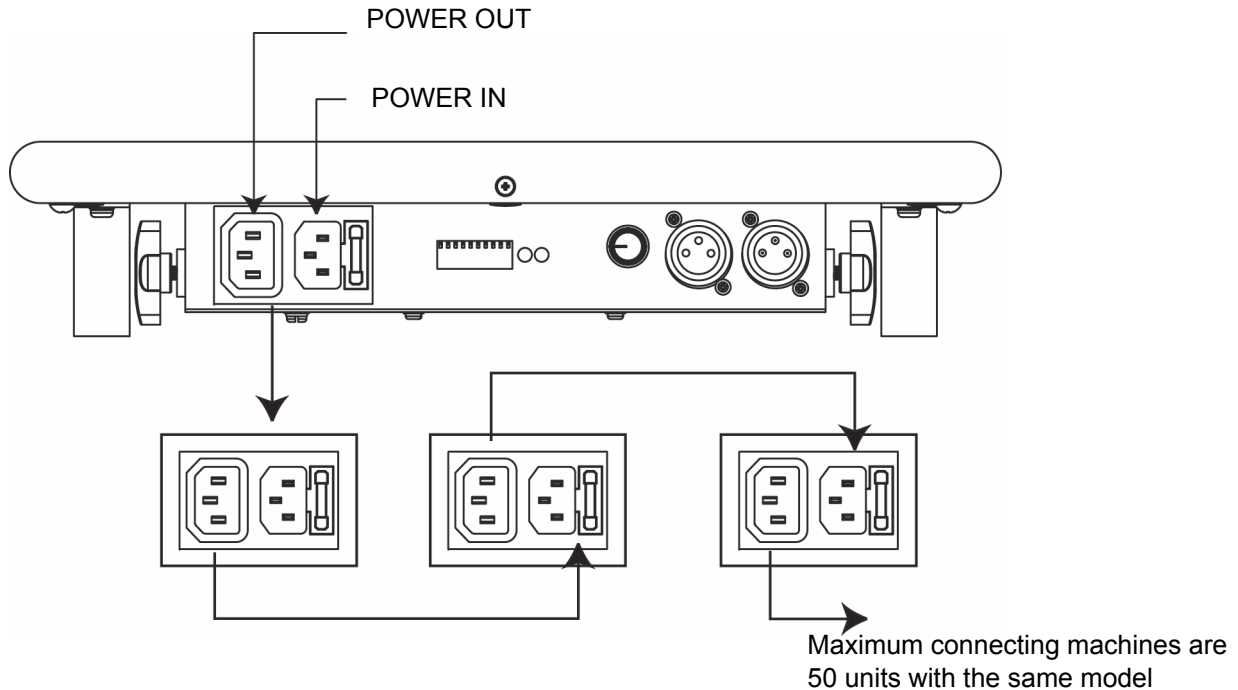

Power supply by storage battery

The storage batteries Wi-Powerhouse provide DC 12V, can be connected through four-pin Airline Terminal without other power supply ,when plug power 100-240V AC, the Wi-Powerhouse will stop supplying power.

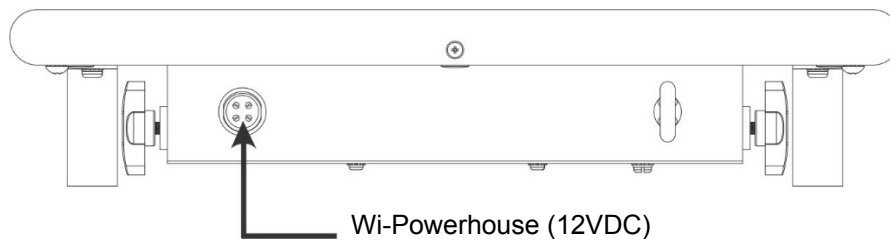

Master/Slave mode

The first unit is master without signal of DMX ,the others connected are slave units and follow the actions of Master.

Master/Slave connection

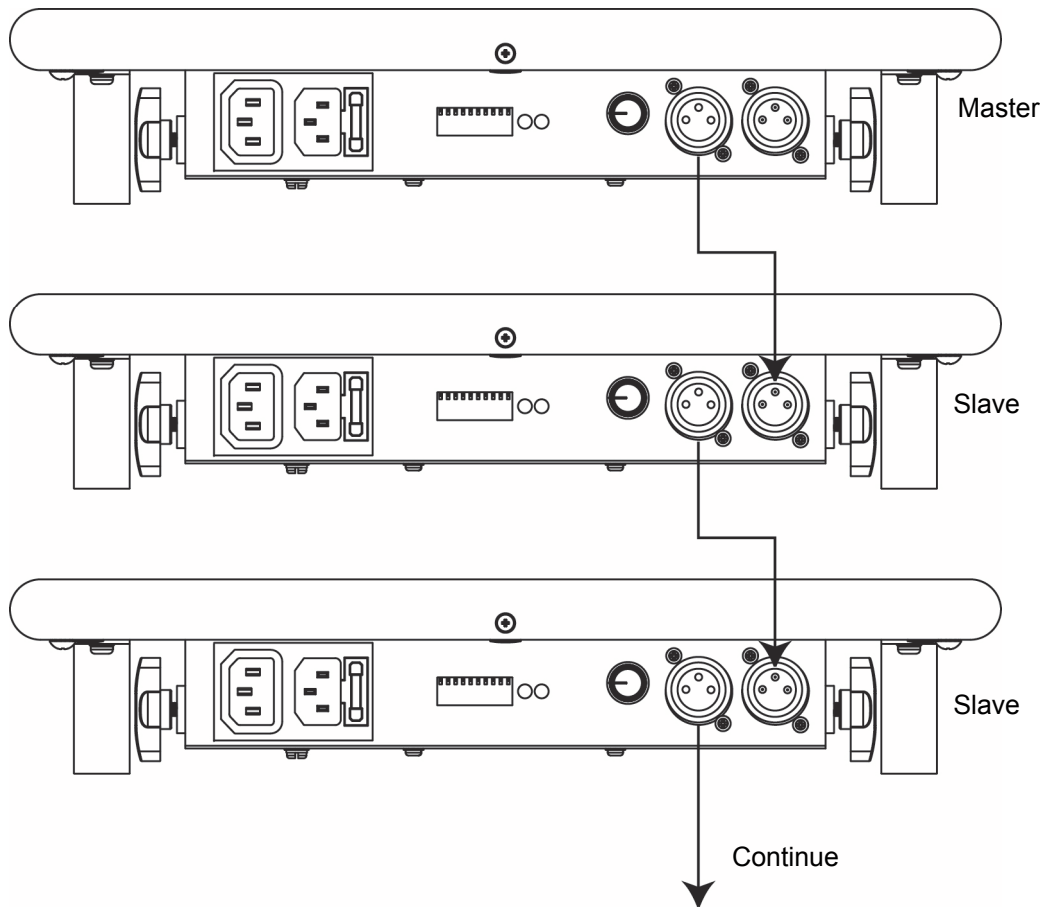

Sound Active Mode

In this mode, DIP 9 is on without DMX or master signal. When many fixtures are connected, the first one acts as master, others connected are slaves and follow the actions of master.

Automatic Mode

In this mode, DIP 10 is on without DMX or master signal. When many fixtures are connected, the first one acts as master, others connected are slaves and follow the actions of master.

DIP switch setup

Mode	DIP Switch
Sound Active Mode	9= ON, 1-8, 10 = OFF
Automatic Mode	10= ON, 1-9 = OFF

Function setup by Dip switch without DMX signal.

DIP1-8 Strobe (slow to fast)

DIP9 Sound active

DIP10 Automatic display

DMX controllable

With three channels, automatic display, sound activated and strobe functions can be controlled by DMX. Speed of strobe and automatic display can be adjusted, LED brightness can also be adjusted.

DMX Value Functions 3 CH

CHANNEL	VALUE	FUNCTION	CH 2	CH 3
1	000 – 039	Strobe	0 – 19 No strobe 10 – 255 Strobe slow-fast	Dimmer 0 – 255 100% - 0%
	040 – 079	Mode 1	Speed 0 – 255 slow - fast	
	080 – 119	Mode 2		
	120 – 159	Mode 3		
	160 – 199	Mode 4		
	200 – 239	Mode 5		
	240 – 255	Sound	No function	

Value setup manual

Each one needs to setup DMX value when multiple fixtures are connected in the mode of DMX512, data of the channels can be read by the value. With three DMX channels is the value setup for the first 001 , 004 for the second one and 007 for the third one.

Diagram of value setup

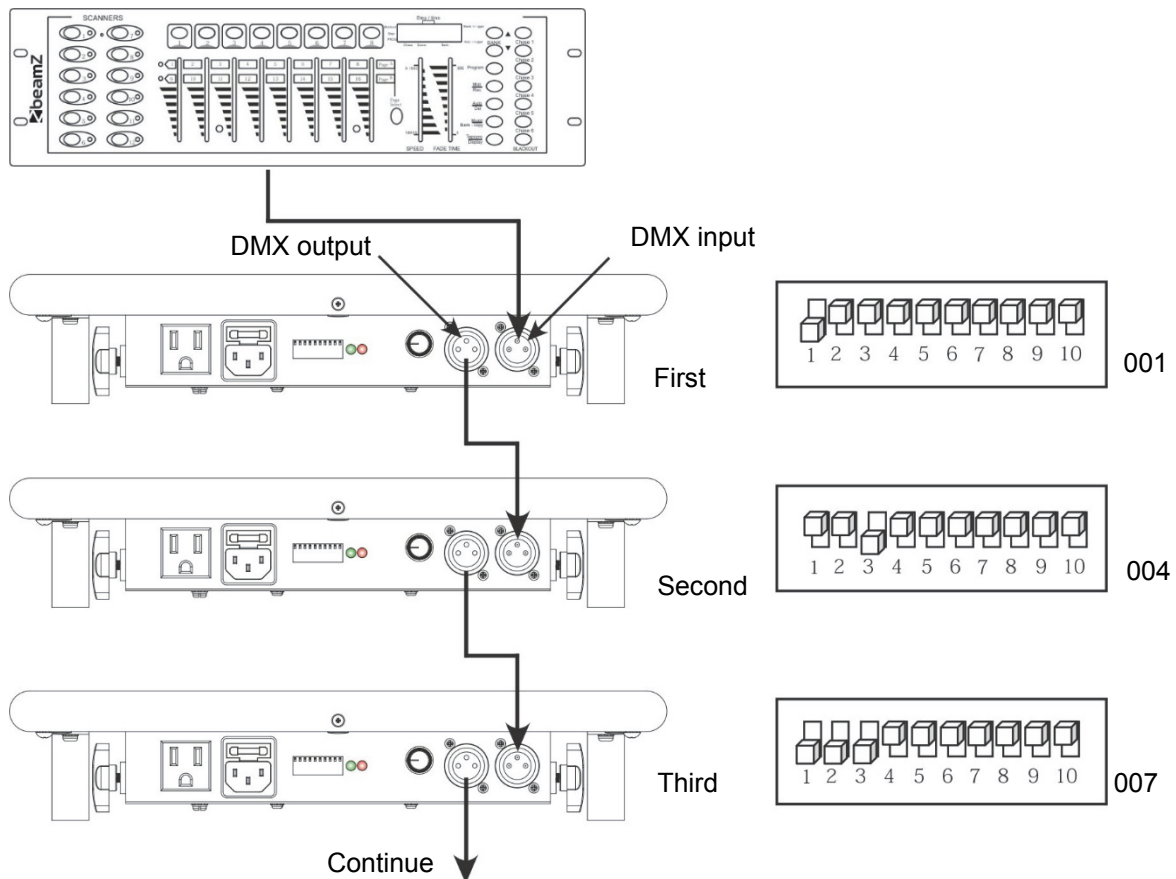

Setting DMX address by Dip switch

The number of channels determines the starting address of each fixture. For example, there are two fixtures with 6 channels and two fixtures with four channels, if the address of two fixtures with 6 channels is ahead of the others, the address of the four fixtures will be 1, 7, 13, 17 separately. If the address of two fixtures with 4 channels is ahead of the others, the address of the four fixtures will be 1, 5, 9, 15 separately.

Address is only set by DIP1 to DIP9 and DIP10 is not be used.

DIP	Addressing
1	1
2	2
3	4
4	8
5	16
6	32
7	64
8	128
9	256

Determining which switches to toggle ON given a specific desired address or value can be accomplished in the following manner. By subtracting the largest switch value possible from the selected start address which does not cause a negative number. For example, if you need to set the starting address of a fixture as 43, firstly put DIP6 (32) on, DIP4 (8) on, and then put DIP2 (2), at last DIP1 (1). Adding the value of each switch in the ON position will provide the final address, which is $32+8+2+1=43$.

Example address is shown as below:

DMX address	DIP on	Value for DIP switch	Diagram
10	DIP 4 DIP 2	8 2 ($8+2 = 10$)	
24	DIP 5 DIP 4	16 8 ($16+8 = 24$)	
233	DIP 8 DIP 7 DIP 6 DIP 4 DIP 1	128 64 32 8 1 ($128+64+32+8+1 = 233$)	

DMX address can be set from 1 to 512 as above.

MAINTENANCE

The unit should be cleaned periodically to ensure the optimum performance, the smudginess can decrease the life of light and the output of light is affected by the dust which can make the machine overheating. In general, make the maintenance at least two times a month. Be sure to power off the unit before cleaning .

Do not clean until the unit recovers normal temperature since high temperature for using, use the lens tissue or soft cotton cloth with alcohol to wipe gently.

Cleaning frequency depends on the environment in which the fixture operates, damp, smoky or dirty surrounding can cause greater accumulation of dirt on the optics. Never rub or press strongly on the panel.

SPECIFICATION

Voltage..... 100-240V AC 50/60Hz
Input current 0.1A
Power..... 12W
Fuse.....2A 250V
Light source 192x 5mm UV LEDs
Weight.....2.5kg
Size.....L356 x W70 x H240mm



tronios
Sound & Light

CE & R&TTE DECLARATION OF CONFORMITY

Importer: TRONIOS BV
Bedrijvenpark Twente 415
7602 KM - ALMELO

Tel : 0031546589299
Fax : 0031546589298
The Netherlands

Product number: 150.664

Product Description: Beamz, LCP-192UV LED Panel UV 192x5mm

Regulatory Requirement: EN 60598-1/-2-17:2009
EN 62031:2008
EN 61347-2-13:2007
EN 62479:2010
EN 55015:2006/A2:2009
EN61547:2009

The product meets the requirements stated in the above mentioned Standards. This certificate does not cover the aspects that may be relevant such as performance and fitness for purpose.

Almelo,

10-03-2012

Signature:

Specifications and design are subject to change without prior notice..

www.tronios.com

Copyright © 2013 by TRONIOS the Netherlands